



**MODEL E ENERGY SAVER**  
LOW WATER  
MACHINES

**USES ONLY  
1.01  
Gallons Of Water  
Per Cycle!**



**MODEL E  
AVAILABLE IN STRAIGHT  
AND CORNER MODEL**



**OPTIONAL 3 DOOR  
MODEL AVAILABLE  
FOR STRAIGHT AND  
CORNER OPERATION**



**MODEL E EXT  
WITH 20-1/2" DOOR OPENING  
AVAILABLE IN STRAIGHT  
AND CORNER MODEL**

**FEATURES AND FACTS:**

- **Energy Star Qualified.**
- 40 racks / 160 covers per hour.
- Economical to operate. **Uses only 1.01 gallons of water per cycle.**
- All stainless steel construction assures long life and years of trouble free operation.
- Unique spray arm system features upper and lower stainless steel wash arms with reinforced end caps.
- Top mounted controls include built-in chemical pumps and delimiting system for dealing with scale.
- Auto start/stop makes operation safe and easy.
- New integrated scrap tray prevents food soil from entering drain system.
- Airgap fill system.

**CONVERTIBLE CORNER TO STRAIGHT AND STRAIGHT TO CORNER.**

**Available Options**

- Sanitizer Alarm
- Alternative cycle times
- Pull Pins
- Stainless Steel Scrap Trap Up Grade
- The "TEMP-SURE" requires a separate 208-240v 3 phase 40 amp power supply
- 3 Doors open
- Extended (Tall) version





# MODEL E ENERGY SAVER

## LOW WATER MACHINES

### WARNINGS:

- Plumbing connections must be made by a qualified service company who will comply with all available Federal, State, and Local Health, Plumbing and Safety codes.
- CMA recommends utilizing a water softening system to maintain water hardness measurements of 3.5 gpg (grains per gallon) or less. This will assure maximum results and optimum operation of the dishmachine.

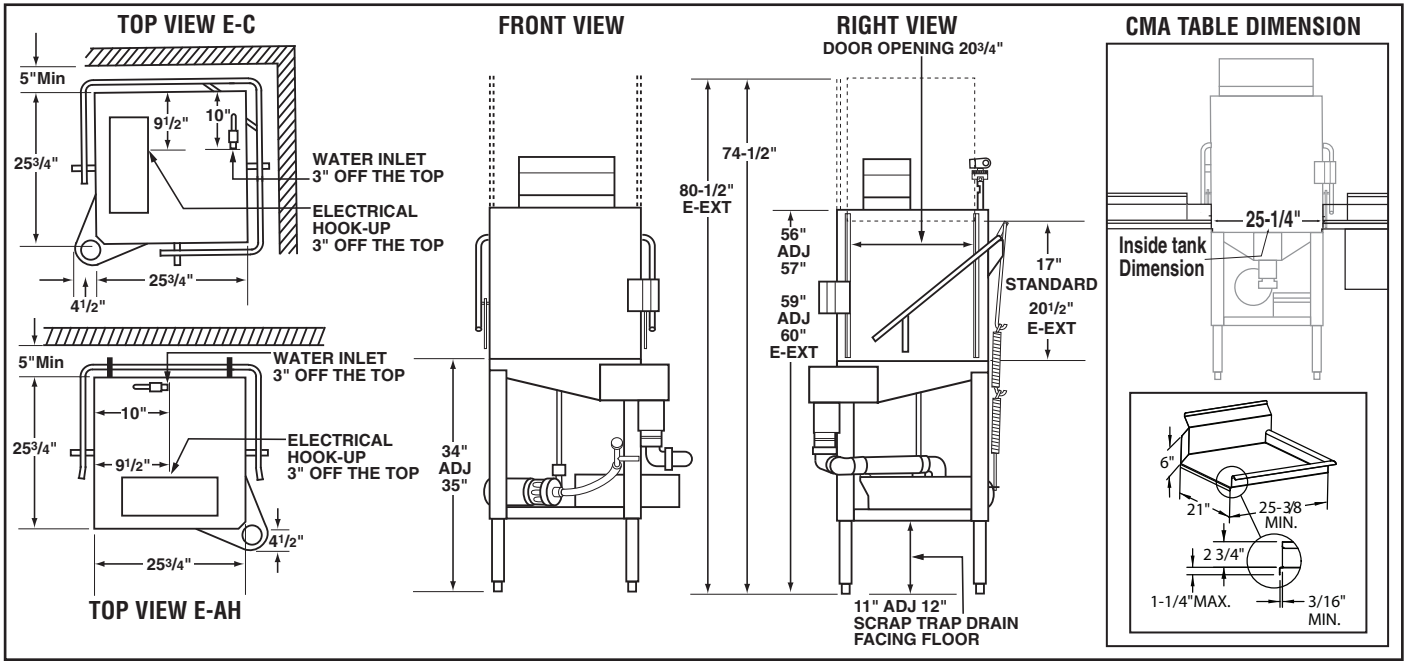

### Specifications:

MODEL E/E-3/E-EXT	USA	METRIC	USA	METRIC
<b>OPERATING CAPACITY</b>				
RACKS PER HOUR (NSF RATED)	40	40		
<b>OPERATING CYCLE</b>				
WASH TIME-SEC	45	45		
RINSE TIME-SEC	30	30		
DWELL TIME-SEC	15	15		
TOTAL CYCLE TIME	90	90		
<b>PUMP CAPACITY</b>	52 GPM	(197 LPM)		
<b>OPERATING TEMPERATURE</b>				
REQUIRED	120°F	(49°C)		
RECOMMENDED	140°F	(60°C)		
<b>WATER CONSUMPTION</b>				
PER RACK	1.01 GAL.	(3.8 L)		
PER HOUR	37 GPH	(140 LPH)		
<b>WATER REQUIREMENTS</b>				
WATER INLET	1/2"	(1.27cm)		
DRAIN-I.P.S.	2"	(5.1cm)		
<b>WASH PUMP MOTORS HP</b>			1	1
<b>DIMENSIONS</b>				
DEPTH	25-3/4"	(65.4cm)		
WIDTH (OUTSIDE DIMENSION)	25-3/4"	(65.4cm)		
TOTAL HEIGHT WITH DOORS OPEN	74.1/2"	(189.5cm)	E-EXT 80.1/2"	(204cm)
STANDARD TABLE HEIGHT	34"	(86cm)		
MAXIMUM CLEARANCE FOR DISHES	17"	(43cm)	E-EXT 20-1/2"	(52cm)
<b>STANDARD DISHRACK DIMENSIONS</b>	1	1		
	19-3/4"X19-3/4"	(50X50cm)		
<b>ELECTRICAL RATING</b>			<b>VOLTS</b>	<b>AMPS</b>
			115	16
<b>APPROXIMATE SHIPPING WEIGHT</b>			E-AH/E-C 225#	(102kg)
			E-3D ???#	(???kg)
			E-AH EXT/E-C EXT 262#	(118.8kg)
			E-3D EXT ???#	(???kg)
<b>SHIPPING DIMENSIONS</b>			PALLET & BOX @ 41" X 41" X 66" (E-AH/E-C & E-3D)	
			EXT PALLET & BOX @ 41" X 41" X 80" (E-AH EXT/E-C EXT & E-3D EXT)	

### Summary Specifications: Model E/E-3/E-EXT

CMA Energy Miser model E/E-3/E-EXT (Extended 20-1/2" door opening) low temperature, chemical sanitizing commercial dishwashers meet ETL, UL, and CUL sanitation and construction standards WITHOUT the use of BOOSTER or TANK HEATERS. The model E/E-3/E-EXT is constructed entirely of stainless steel. Each unit automatically washes, rinses and sanitizes utensils in standard 19-3/4"x19-3/4" racks. Units come with standard upper and lower stainless steel wash arms. **Note: This machine does not have built-in heaters, therefore produces no steam.**

**Advisory:** CMA does NOT endorse "Tankless On-Demand" water heaters for use on CMA Dishmachine products. CMA DOES endorse, and highly recommends, the standard "tank" style water heaters, sized properly to handle each particular facility with their water heating requirements.



CMA Dishmachines 12700 Knott Street Garden Grove, CA 92841 • 800-854-6417 • 714-898-8781 • Fax: 714-895-2141 • www.cmadishmachines.com

CMA reserves the right to modify specifications or discontinue models without prior notification.

P/N: 10124.01

© 3-2018 CMA, Inc.

an All Group Company



The Spirit of Excellence