



310 SERIES

Undercounter Ice Machines

URP0310A | UDP0310A | UDP0310W | UYP0310A | UYP0310W



ICE SHAPES



▶ **Half-Dice:** 3/8" x 1 1/8" x 7/8"
(0.95 x 2.86 x 2.22 cm)



▶ **Dice:** 7/8" x 7/8" x 7/8"
(2.22 x 2.22 x 2.22 cm)



▶ **Regular:** 1 1/8" x 1 1/8" x 7/8"
(2.86 x 2.86 x 2.22 cm)

SIZE

- ▶ Up to 330 lbs (150 kgs) of daily ice production
- ▶ 30" (76.20 cm) wide, 28.50" (72.4 cm) deep, and 38.50" (97.8 cm) high on 6" (15.24 cm) legs
- ▶ 3.99 ft³ (0.113 m³) cabinet volume
- ▶ 119 lb (54 kg) ice storage capacity*

*Application capacity based on 90% volume x 33 lbs./ft³ average density of ice

SPECIFICATIONS

Refrigerant R290

BTU Per Hour

- ▶ 5,500 (average)
- ▶ 6,500 (peak)

Compressor: Nominal rating 0.5 HP

Cupra-Nickel Condenser: (Water-cooled models)
Adds protection from corrosive water elements

Operating Limits:

- ▶ Ambient temperature range: 50° to 100°F (10° to 37.7°C)
- ▶ Water temperature range: 45° to 90°F (4.4° to 32.2°C)
- ▶ Water pressure ice maker
 - ◆ Water in
 - Min. 20 psi (137.9 kPa)
 - Max. 80 psi (551.1 kPa)
- ▶ Condenser inlet water in
 - ◆ Water-cooled only
 - Min. 20 psi (137.9 kPa)
 - Max. 150 psi (1,034.2 kPa)

Power

115/60/1 (208-230/60/1 and 230/50/1 available) 115/60/1 ice machines are factory pre-wired with a 8 ft (243 cm) power cord and NEMA 5-15P-plug configuration. 208-230/60/1 ice machines are factory pre-wired with a 8 ft (243 cm) power cord only, no plug is supplied.

Total Amps

- ▶ 115/60/1 Air-cooled 8 amps, Water-cooled: 7 amps
- ▶ 208-230/60/1 Air-cooled: 5 amps

Maximum Fuse Size

- ▶ Air and water-cooled: 15 amps
- ▶ HACR-type circuit breakers can be used in place of fuses



Touchpad

Easy to read and use touchpad - on/off, delay, clean, filter change, full bin, service indicator



Onboard Water Filtration

Integrated water filtration improves machine efficiency and performance while ensuring cleaner, clearer, and great-tasting ice



Air Flow

Front ventilation is ideal for installation under countertops or next to other equipment



Removable Bin

Removable, forward-sliding storage bin allows for easy access to refrigeration components for cleaning and maintenance

NEO® 310 SERIES

Undercounter Ice Machines

URP0310A | UDP0310A | UDP0310W | UYP0310A | UYP0310W

INSTALLATION

Recommended clearance for top, sides and back is 5" (12.7 cm) however, there is no minimum clearance required.

- A** 3/8" (0.95 cm) F.P.T. Ice Making Water Inlet
- B** 1/2" (1.27 cm) F.P.T. Ice Making Water Drain
- C** 3/8" (0.95 cm) F.P.T. Condenser Water Inlet
- D** 1/2" (1.27 cm) F.P.T. Condenser Water Drain
- E** 1/2" (1.27 cm) F.P.T. Bin Water Drain
- F** Electrical Entrance

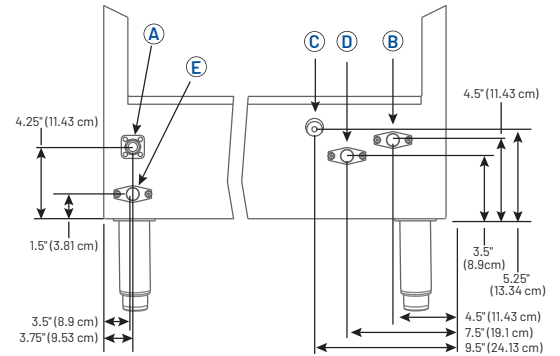
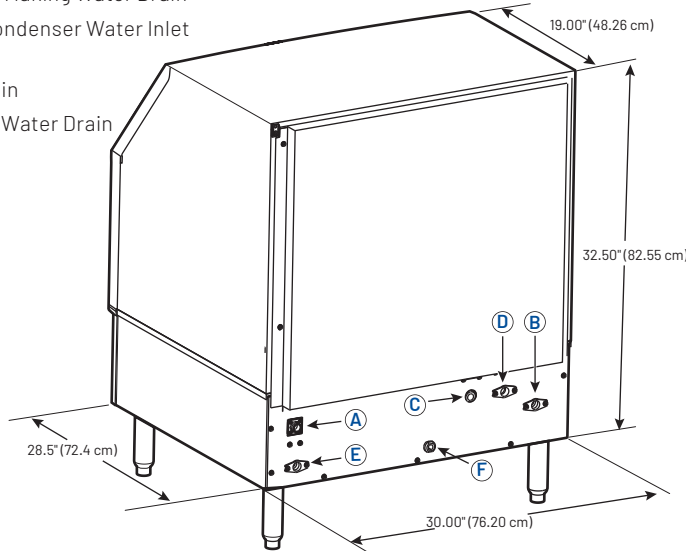

Limited Commercial Warranty

Ice Maker Three (3) years parts and labor

Evaporator Five (5) years parts and labor

Compressor Five (5) years parts, three (3) years labor

SPECIFICATIONS

Model	Ice Shape	Ice Production 24 Hours				Power Usage kWh per 100 lbs. of ice	Potable water usage gal/100 lbs. ice @ 90° Air/70°F Water (32° Air/21°C Water)
		70° Air/50°F Water 21° Air/10°C Water		90° Air/70°F Water 32° Air/21°C Water			
URP0310A	Regular	300 lbs	136 kg	245 lbs	111 kg	5.85	15.5 gal (58.67 L)
UDP0310A	Dice	315 lbs	142 kg	263 lbs	119 kg	5.85	15.5 gal (58.67 L)
UDP0310W	Dice	300 lbs	136 kg	280 lbs	127 kg	4.66	15.5 gal (58.67 L)
UYP0310A	Half-Dice	330 lbs	150 kg	270 lbs	122 kg	5.85	15.5 gal (58.67 L)
UYP0310W	Half-Dice	310 lbs	140 kg	290 lbs	132 kg	4.66	15.5 gal (58.67 L)

Water-cooled condensers: Water Usage / 100 lbs (45.4 kg) of Ice: 160 gal (605 liters)
Standard 6" (15.24 cm) adjustable leg. Standard plastic NEO ice scoop included.



2110 South 26th Street | Manitowoc, WI 54220 | United States
+1.920.682.0161 | 920.683.7589 Fax | manitowocice.com

All indicated Pentair trademarks and logos are property of Pentair. Third party registered and unregistered trademarks and logos are the property of their respective owners. ©2025 Pentair. All rights reserved.